



Warrick® Series 3S Fitting Installation and Operation Bulletin

The series 3SXXX electrode fitting is designed to provide isolation of electrodes from liquids containing greases, soaps, oils, sludge, rags, paper and other debris commonly found in sewage and sump drainage and also waste disposal and treatment systems.

The isolation of the electrodes is accomplished by enclosing them within a 1-1/2 inch pipe assembly which also incorporates a neoprene flexible bulb on the lower end of the pipe assembly. The bulb houses 3-1/2 quarts of water and one ounce of sodium bicarbonate (baking soda).

Since the bulb is flexible, the hydrostatic pressure of the water inside the bulb will always equal the hydrostatic pressure of the liquid outside of the bulb. Then, assuming the density of the liquid outside the bulb to be the same as water, the height of the head of water inside the bulb must always duplicate the height of the head of the liquid outside of the bulb. When liquids having densities other than that of water are to be controlled, the electrodes are simply positioned at somewhat higher or lower levels to compensate for the differences in densities.

The fitting is shipped in three assemblies. These include (a) the flexible bulb assembly, (b) the terminal housing assembly and (c) the pipe assembly. In order to install, proceed as follows:

Remove the protective caps from the 1-1/2 inch pipe. Examine the inside of the pipe for foreign material and clean if required.

Remove tape and unwind the electrodes and suspension wire hooked to the terminal housing assembly. Place the assembly on floor and extend electrodes to their extreme position. Eliminate kinks and twists between wires. Position electrodes to proper elevation. Note: electrode lengths are measured from the bottom of the flange. To set or change electrode positions, loosen the 3/8" bushing located inside the terminal housing. (there is sufficient suspension wire inside the terminal housing to allow each electrode to be lowered to a maximum of 12" from set position) Lowest electrode is already positioned at the lower end of the 1-1/2" pipe and should not be lowered any further.

Screw the flexible bulb assembly to the bottom of the 1-1/2" pipe. Be sure to use either a pipe thread compound or Teflon tape to insure a watertight connection. If desired, the bulb assembly need not be until the pipe assembly has been placed and secured in permanent position. This can only be done in locations where bulb assembly can be attached from inside the sump. For protection and ease of installation, fold the flexible bulb into a compact bundle about its vertical axis and tape it to secure it.

Slowly guide the electrodes and suspension wires through the 1-1/2 inch pipe assembly. The longest electrode will enter first, then the next longest, etc., until all have been accommodated. Engage the male thread on the pipe assembly with the coupling on the flange assembly and tighten with a wrench.

Remove the tape from the flexible bulb. Carefully lower the electrode assembly, bulb first, through the opening in the cover over the basin until the flange rests on the basin cover.

Remove terminal housing lid and install conduit from the housing to the control box. Note: distance between control and electrode fitting should not exceed 100 feet. Pull the necessary wires between the control and the electrode fitting using #14 AWG wire. Connect the control wires to the electrode suspension wires using control wiring diagram as a source of reference for appropriate wire to electrode identification. Replace the terminal lid on the terminal housing.

Fill the basin with water to a level approximately 4 inches below the cap to which the bulb is attached. Remove the pipe plug from the 3/8 inch street ell located near the terminal housing and pour in 3-12 quarts of water and one ounce of sodium bicarbonate (baking soda). Note: The design and operation of the fitting along with the control is such that the longest electrode should never be immersed when the level in the basin is below the elevation of that electrode. Therefore care should be used to avoid overfilling the bulb. Replace pipe plug when finished.

Installation of the controller is now completed and the level within the 1-1/2 inch pipe will duplicate the liquid level in the basin, actuating the controls as the liquid rises and falls by making and breaking contact with the electrodes.

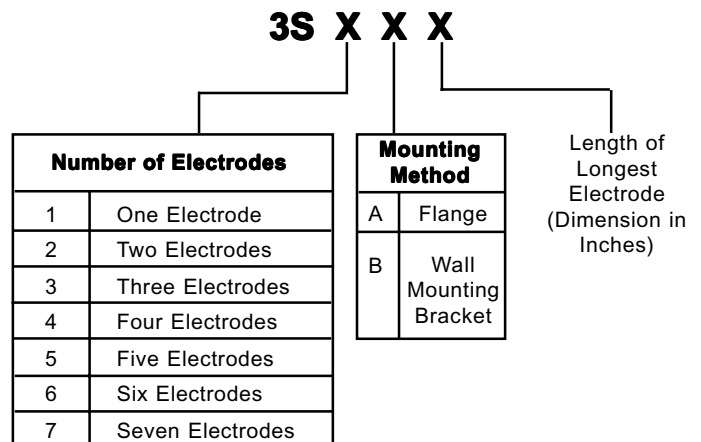

Note
When ordering, list all electrode lengths for factory setting

Flexible Bulb- Flange Mount

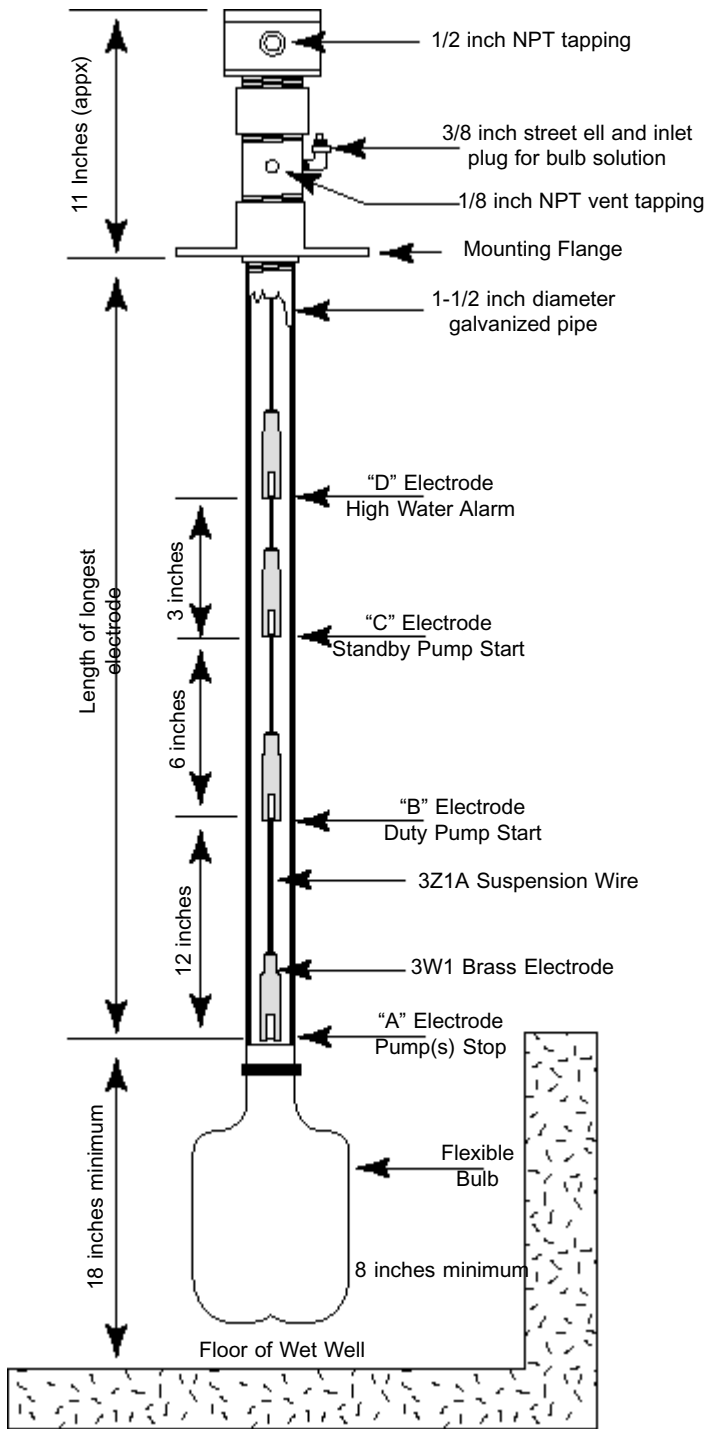

3/4 dia mouting holes

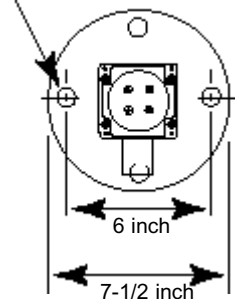

Flexible Bulb- Wall Mount

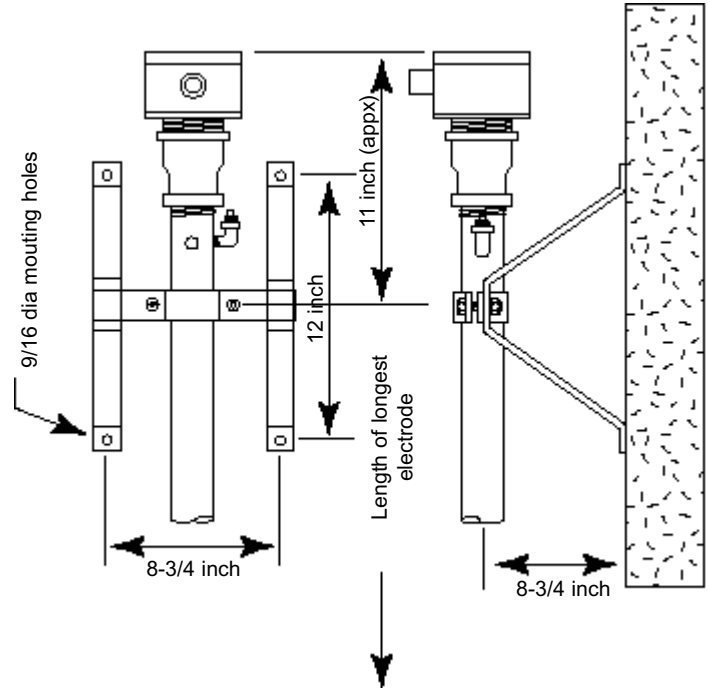

Note 1: The maximum operating range possible between the longest electrode and the shortest electrode is 7 feet. For greater operating ranges consult the factory for details on dual flexible bulb assemblies.

Note 2: When basin depth exceeds 20 feet, the 1-1/2 inch pipe should be supported by wall brackets.

Note 3: Individual 3Z1A suspension wires in terminal housing have identifying wire markers "A", "B", "C" etc. Wire "A" is attached to the lowest electrode, wire "B" is attached to the next longest electrode, etc.

Note 4: The flexible bulb should contain 3-1/2 quarts of water and one ounce of sodium bicarbonate (baking soda).

Note 5: Electrode designations are typical for a duplex pump down control with high water alarm.



Gems Sensors Inc.
One Cowles Road
Plainville, CT 06062-1198
Tel: 860-793-4579
Fax: 860-793-4580