

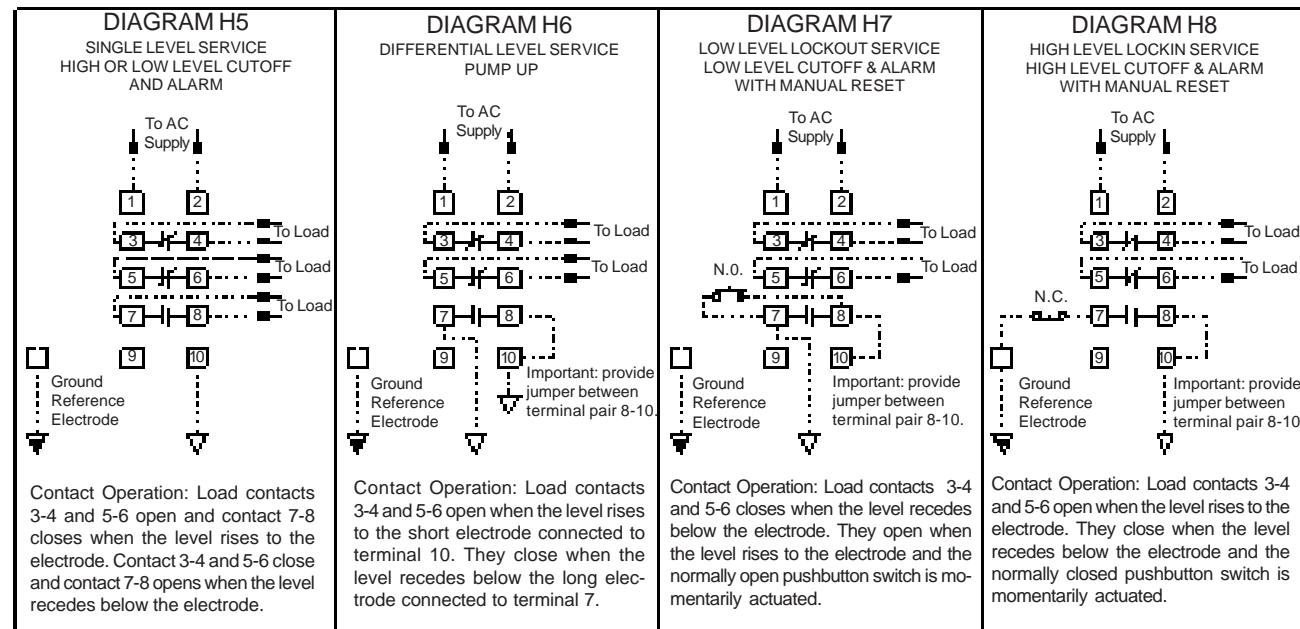

## Warrick® Series 2 Solid-State Electromechanical Controls Installation and Operation Bulletin

This bulletin should be used by experienced personnel as a guide to the installation of Series 2 controls. Selection or installation of equipment should always be accompanied by competent technical assistance. We encourage you to contact Gems Sensors or its representatives if further information is required.

**IMPORTANT!**  
Before proceeding to install the control,  
Read and thoroughly understand these instructions.

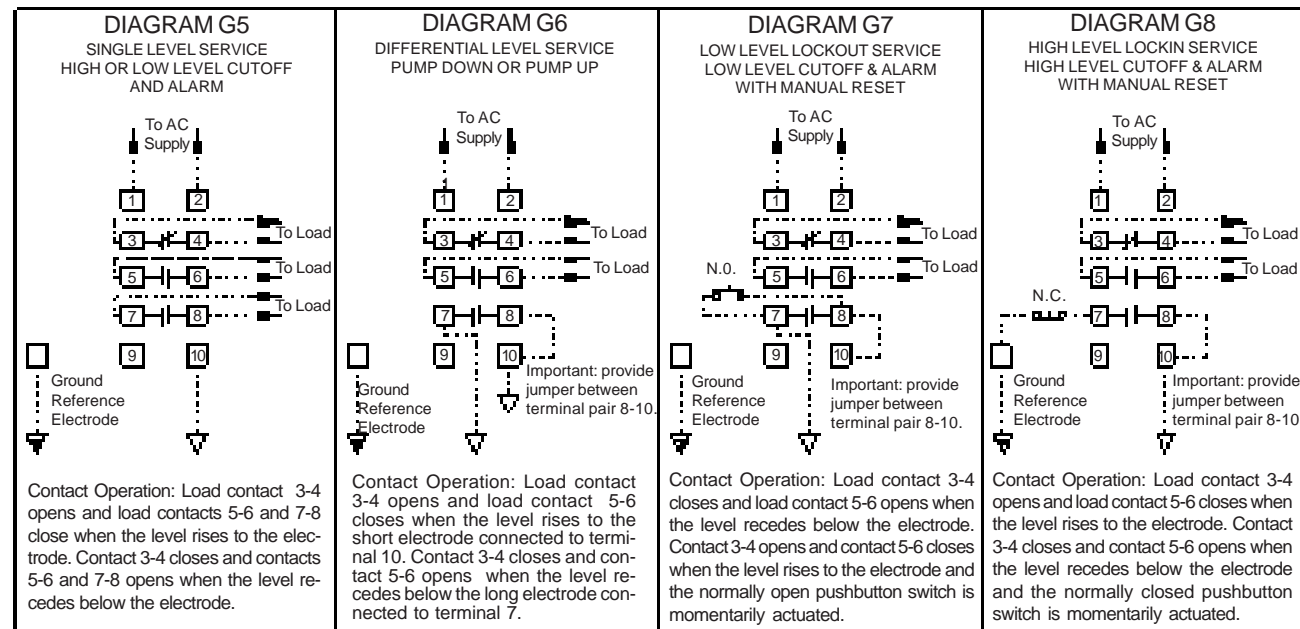
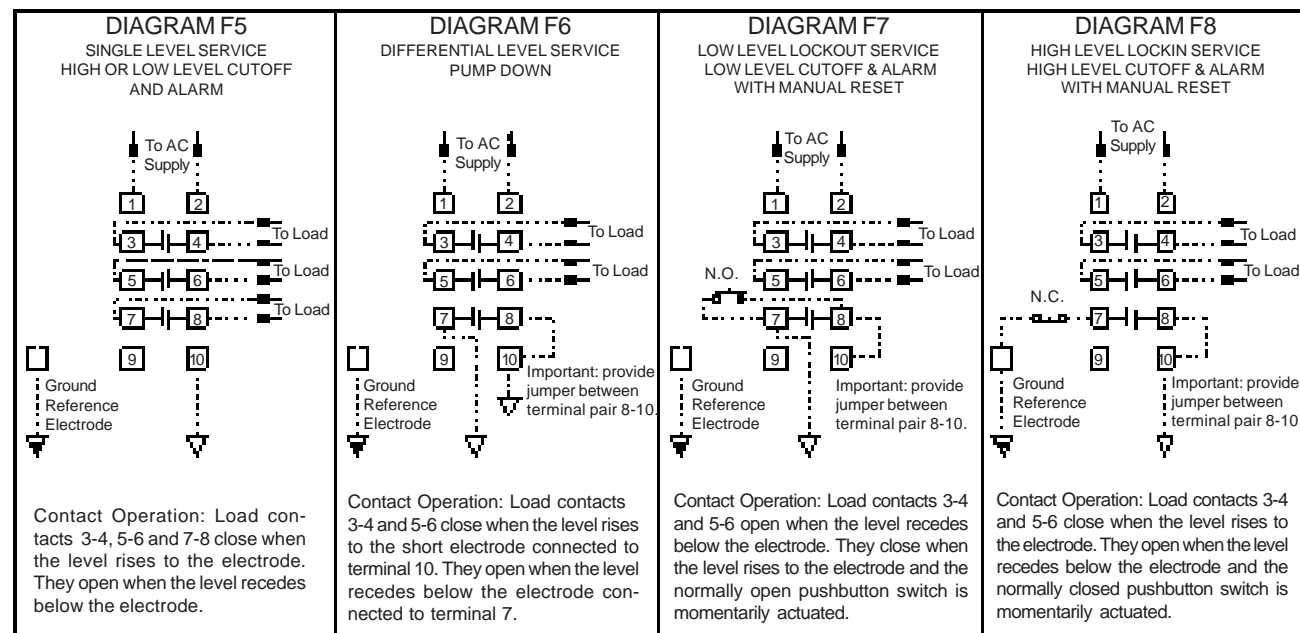

### General

Series 2 controls are simple solid-state industrial type controls with field adjustable sensitivity. They contain 2 or 3 pole contacts with high contact ratings. The solid-state/ relay combinations allow for multiple primary voltages and a low 10VAC secondary voltage. They are suitable for use in non-hazardous locations with conductive liquids less than 100,000 Ohm/cm specific resistance.

**Secondary Voltage:** 10 VAC RMS with open circuit on probes.

**Secondary Current:** 6VA with short circuited electrode circuit.

**Sensitivity:** Models operate from 470 to 100,000 OHM maximum specific resistance – Factory Set and Field Adjustable.

**Temperature:** -30 to +130°F ambient.

**Terminals:** #8 pan head screw with captivated wire clamping plate. Maximum of 1 – #12 or 2 - #14 AWG prepared wires per terminal. Use prepared conductors only, when wiring this control.

**Time Delays:** NONE

**Listings:** Open and Enclosed Type – UL listed (File E44426, Motor Controls Misc.)

### Specifications

**Control Design:** Solid-State Electrical-Mechanical level relay for use with conductivity probes.

**Contact Design:** 2 or 3 SPST (Non-Powered): Offered in both N.O. and N.C. - See contact configuration chart.

**Contact Rating:** 16A @ 115VAC; 8A @ 230VAC, 1H.P. @ 115 of 230 VAC

**Supply Voltage:** 115,230,460,575 nominal, plus 10%, minus 15%, 50/60 Hz.

**Supply Current:** 115,230,460,575 VAC, Relay energized draws 15VA.

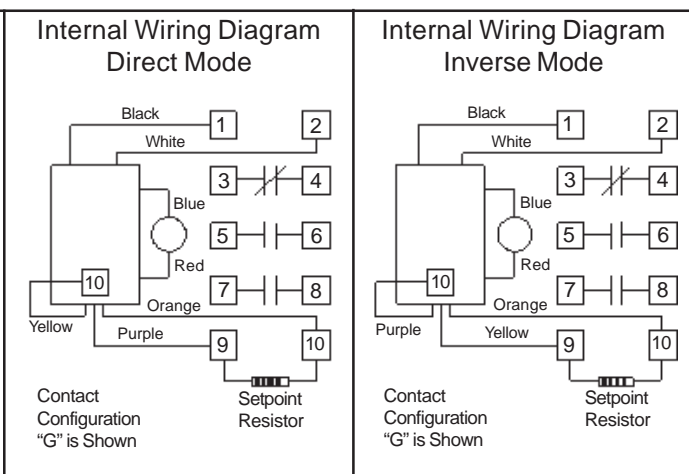
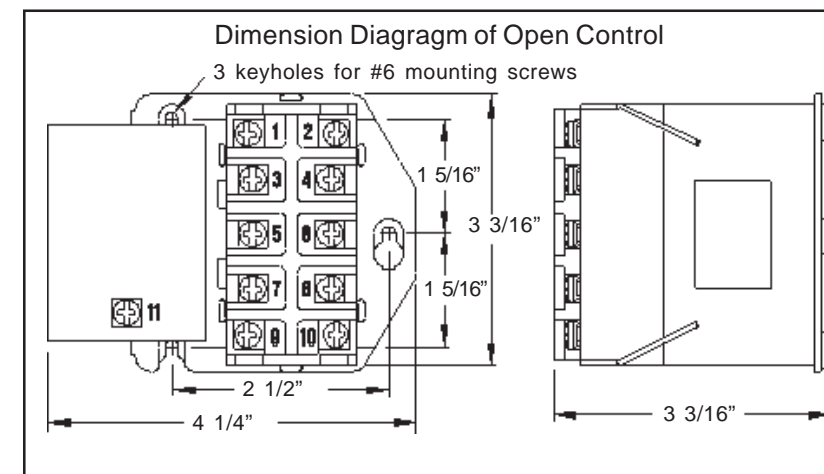

## Application Table

Basic Service	Function	**Required Electronics	Wiring Diagram	Contacts^^		
				Symbol^	N.O.	N.C.
Single Level	High Level Alarm or Low Level Cutoff	2	C5	C	2	0
			F5	F	3	0
	High Level Cutoff or Low Level Alarm	2	E5	E	0	2
			J5	J	0	3
	High or Low Level Cutoff or Alarm	2	D5	D	1	1
			G5	G	2	1
Differential Level	Pump Down	3	C6	C	2*	0
	Pump Up	3	F6	F	3*	0
			D6	D	1*	1
Pump Down or Pump Up	3	H6	H	1*	2	
Low Level Lockout	Low Level Alarm with Manual Reset	2	G6	G	2*	1
	Low Level Cutoff with Manual Reset	2	D7	D	1*	1
			H7	H	1*	2
Low Level Cutoff and Alarm with Manual Reset	2	C7	C	2*	0	
High Level Lockout	High Level Alarm with Manual Reset	2	F7	F	3*	0
			G7	G	2*	1
	High Level Cutoff with Manual Reset	2	D8	D	1*	1
High Level Cutoff and Alarm with Manual Reset	2	H8	H	1*	2	
High Level Cutoff and Alarm with Manual Reset	2	G8	G	2*	1	

- \* One normally open contact required to seal electrode circuit. Number of normally open contacts available for load duty therefore one less than figure indicated.
- \*\* Terminal 11 of control assumed connected to a reference electrode. Terminal 11 may be grounded to the vessel if the vessel is metallic.
- ^ Letters represent 2nd place symbol in the component number of the control.
- ^^ All contacts available for load duty unless otherwise indicated by footnote.

### Mounting and Wiring Instructions

The Series 2 control may be wired in various ways. Select the wiring diagram, on pages 3 and 4, that matches the contact configuration of your model number and your application. The Application Table on this page can assist you in determining which wiring diagram to use. These controls are not intended for use with programmable controls.

**The Series 2 control must be mounted on a vertical surface with terminal 11 on the left-hand side.** The control should be mounted in an enclosure of proper Nema integrity and wired following N.E.C. and local codes. Terminals on the control are numbered and are in the same relative position as the terminals shown in the wiring diagrams.

### Mounting and Wiring Instructions cont.

Each control has a data label above terminal 11 on top of the control. Terminal pair 1-2 must be continuously energized from an AC supply line of the same electrical characteristics as shown on the data label. Each dry contact used for load duty must be wired in series with the load, and that series branch connected across a power source compatible with the load.

### Grounding:

Series 2 controls mounted in an enclosure have a grounding terminal and wires provided for adequate grounding of the control and conduit entrances to any external metal parts that may become energized. Conduit connections on fiberglass enclosures must be connected via the green ground wire provided for in the enclosure. **Caution:** Bonding between conduits must be made.

Wiring must be provided to the electrodes as shown. Terminal 11 is a reference electrode termination and may be grounded to the vessel if the vessel is metallic. When the vessel is non-metallic, terminal 11 must be connected to an additional electrode of a length equal to, or longer than, the longest electrode used in the vessel. If the electrode fitting used has a metallic body and is supported directly upon a metallic vessel, the ground reference connection is facilitated by securing that end of the reference conductor beneath the head of one of the four screws which fasten the terminal housing to the body of the fitting. The jumper between terminal pair 8-10 and the pushbutton switch wiring on diagrams X2, X3 and X4 are required field connections.

The control-to-fitting wire distance should not exceed those listed in the sensitivity chart located on page 2.

### Series 2 X X X X - 2Z1X

Contact Configuration			AC Line Voltage		Secondary Voltage		Enclosure		Setpoint Value		
Letter	N.O.	N.C.	#	Voltage	Letter	Sec. Volts	#	Type	Letter	Resistor Value (ohm)	Dist/FT*
C	2	0	1	115 VAC	F	10	0	OPEN	A	470	12,500
D	1	1	2	230 VAC			1	NEMA 1	B	1,000	5,000
E	0	2	4	460 VAC			4	NEMA 4	C	2,200	2,300
F	3	0	5	575 VAC					D	4,700	1,300
G	2	1							E	10,000	500
H	1	2							F	22,000	230
J	0	3							G	47,000	125
									H	100,000	50

\* Distance based on 14 AWG wire type THHN or MTW

**Note:** For liquids of known specific resistance choose a sensitivity greater than and closest to that value in ohm/cm.

## Dashed Lines Represent Field Wiring

