

## In-Line Flow Switches FS-380 Series

### Installation

All NPT threads should be installed using a suitable thread sealant (Teflon® tape or Permatex “No more Leaks”®). Sealant must be kept out of unit during installation. Ten diameters of straight run piping are recommended upstream and downstream of the flow sensor.

The FS-380 end fitting is threaded to the body at assembly and torqued to 25 Ft. Lbs. If disassembly from a system is required, it is advisable to hold the end fitting hex with a wrench to prevent sensor disassembly. If the sensor should become disassembled, as a result of uninstalling, retorque the end fitting to 25 Ft. Lbs.

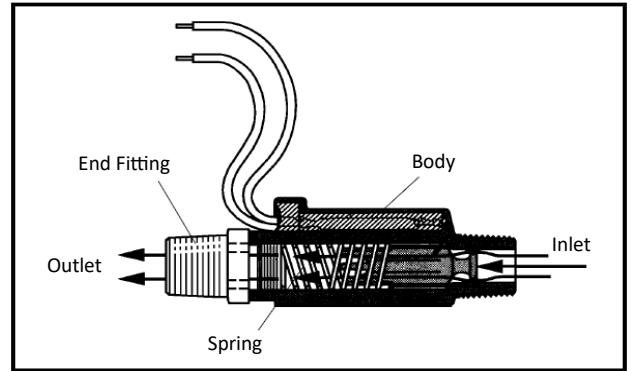

### Specifications

<b>Wetted Materials</b>	
Housing	Brass or Stainless Steel
Piston	PPS Composite
Spring	316 Stainless Steel
<b>Oper. Pressure, Max.</b>	
1500 psi	
<b>Operating Temperature</b>	
-20°F to +275°F (120°C), (-28.8°C to +135°C)	
<b>Required Filtration</b>	
100 Micron or Better	
<b>Set Point Accuracy</b>	
±20%, Maximum	
<b>St Point Differential</b>	
20% Maximum	
<b>Switch, See “Switch Ratings”</b>	
SPST, 20 VA	
<b>Inlet/Outlet</b>	
3/8" NPT Male	
<b>Electrical Termination</b>	
No. 22 AWG, 24" to 26" Polymeric Leads	

### FS-380 Flow Switches Can be Mounted in Various Positions

Flow settings are based on a horizontal position, using water at +70°F on increasing flow. Some variation in set point actuation will occur in other mounting orientations.

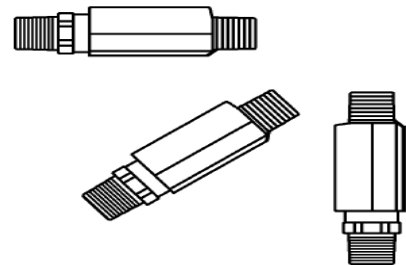

**Pressure Drop—Typical**

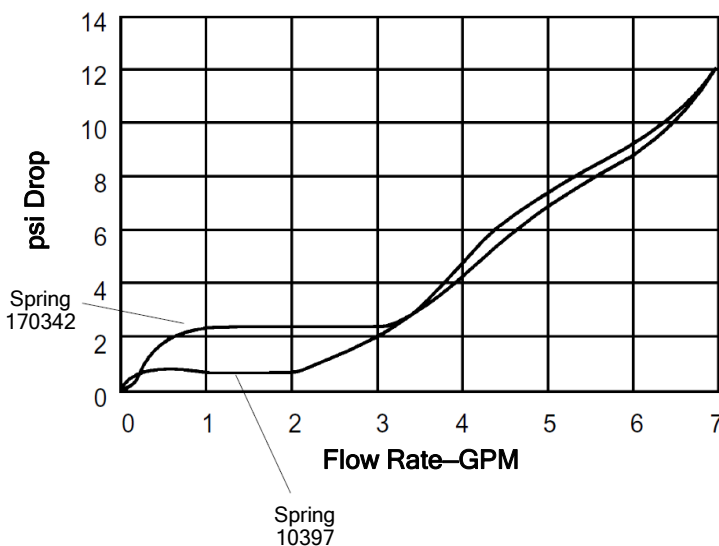

**Switch Ratings**

VA	Volts	Amps A.C.	Amps D.C.
20	0-30	.4	.3
	120	.17	.13
	240	.08	.06

**Wiring Diagram**

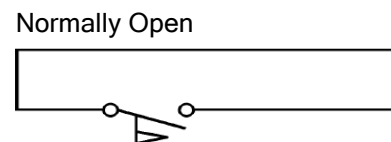

**Max. Resistive Load**

## Dimensions

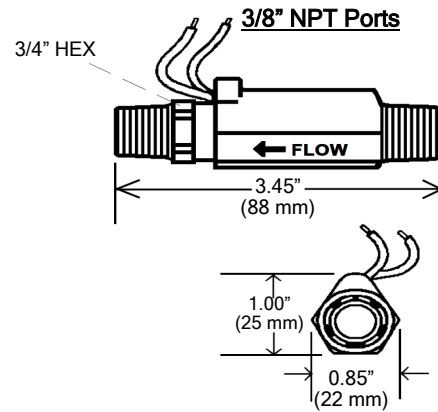
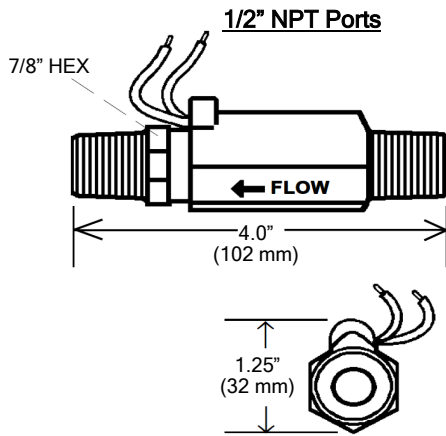

### 3/8" Tube End Compression Fitting

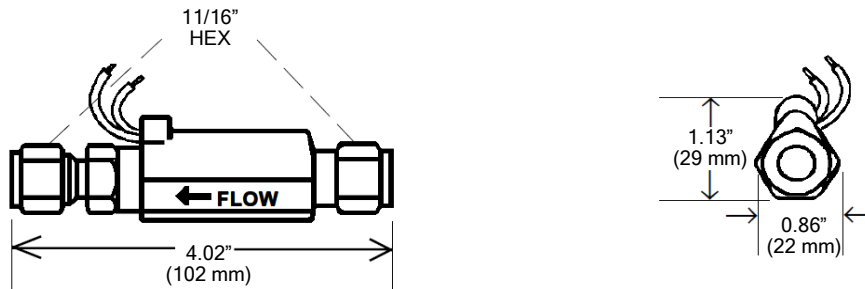

## Important Points!

- Gems product must be maintained and installed in strict accordance with the National Electrical code and Gems product instruction bulletin that covers installation, operation and proper maintenance. Failure to observe this warning may result in serious injuries or damages.
- An appropriate explosion-proof enclosure or intrinsically safe interface device must be used for hazardous area applications involving such things as (*but not limited to*) ignitable mixtures, combustible dust and flammable materials.
- Please adhere to the pressure and temperature limitations shown throughout this catalog for our level and flow sensors. These pressures and temperatures take into consideration possible system surge pressures/temperatures and their frequencies.
- Selection of materials for compatibility with the media is critical to the life and operations of Gems products. Take care in the proper selection of materials of construction, testing is required.
- NSF-approved sensors are made of materials approved for potable water applications according to Standard 61.
- Stainless steel is generally regarded as safe by NSF and FDS.
- Life expectancy of switch contacts varies with applications. Contact Gems if life cycle testing is required.
- Ambient temperature changes do affect switch set points, since the specific gravity of a liquid can vary with temperature.
- Our sensors have been designed to resist chock and vibration. However, shock and vibration should be minimized.
- Liquid media containing particulate and/or debris should be filtered to ensure proper operation of Gems products.
- Electrical entries and mounting points may require liquid/vapor sealing if located in an enclosed tank.
- Our sensors must not be field repaired.
- Physical damage sustained by the product may render it unserviceable.



This product is suitable for Class I and Class II applications only, per the requirements of standard EN60730 and any additional specific requirements for a particular application or medium being sensed. Class I compliance of metal bodied units requires a ground connection between the metal body and the earthing system of the installation. Class I compliance of plastic bodied units in contact with a conductive medium requires that the medium be effectively earthed so as to provide an earthed barrier between the unit and accessible areas. For class III compliance, a supply at safety extra-low voltage (SELV) must be provided. Please consult the Factory for compliance information on specific part numbers.