

General Instructions

These instructions provide information for installation, process connection, electrical connection, operation and maintenance of 3800 Pressure Transmitters. The 3800 Pressure Transmitter consists of a field proven sputtered thin film stainless steel pressure transducer and a reliable electronic circuit. The housing features a stainless steel construction.

The 3800 is capable of powering long cable lengths. See Formula on page 3 for maximum loop resistance.

NOTE: If you suspect that an instrument is defective, contact the factory or the representative in your area for a return authorization number (RMA). This product should only be installed by trained and competent personnel.



Table of Contents

Design and specifications are subject to change without notice.

For latest revision, go to gemssensors.com

Installation	1
Additional Install Steps for Dual Seal Units....	2
Electrical Termination - 3800-C	3
Electrical Termination - 3800-V	4
Operation.....	5
Dimensions	5
Maintenance	6
ATEX Marking Details	7

Installation

Ensure that wiring conforms to all applicable local and national electrical codes and install unit(s) according to relevant national and local safety codes.

Normally, line mounting provides adequate support for the instrument.

1st Step: Make the Process Connection

- 1 The process connection is threaded onto a fitting within an adequately supported process piping system.
- 2 Use two open end wrenches when connecting the pressure port to a process piping system: one wrench to hold the process fitting, the other at the hex flat to tighten the pressure transmitter.
- 3 Process connection pipe or tubing may be rigid or flexible.

NOTE: Do not use the 1/2" NPT(M) connection on pressures higher than 5000 psi.

2nd Step: Make the Electrical Connection

- 1 The electrical connection may be installed on an adequately supported rigid conduit system. Use suitable locknuts (not provided) when mounting the instrument to an unthreaded (knockout) hole.
- 2 Securely connect the conduit pipe or fitting by holding the flats on the electrical connection while tightening.
- 3 Electrical connection may be rigid or flexible conduit.



Unit in Hazardous Locations - Prior to removal from service, make sure that the work area is declassified. Failure to do so could result in severe personal injury or substantial property damage.

Additional Install Steps for Dual Seal Units

Failure to follow these additional installation instructions may diminish the “Ingress Protection” and “NEMA” ratings of the “Dual Seal” instruments. An improper installation will void the warranty.

Vertical Installation

- 1 The figure on the right depicts the vertical installation profile; with the electrical leads on top. The instrument may be installed with the electrical leads on the bottom.
- 2 The nameplate (tag) should cover the set screw (annunciation path). Position the nameplate slot opposite the set screw; i.e., the nameplate slot should be located 180° from the set screw.

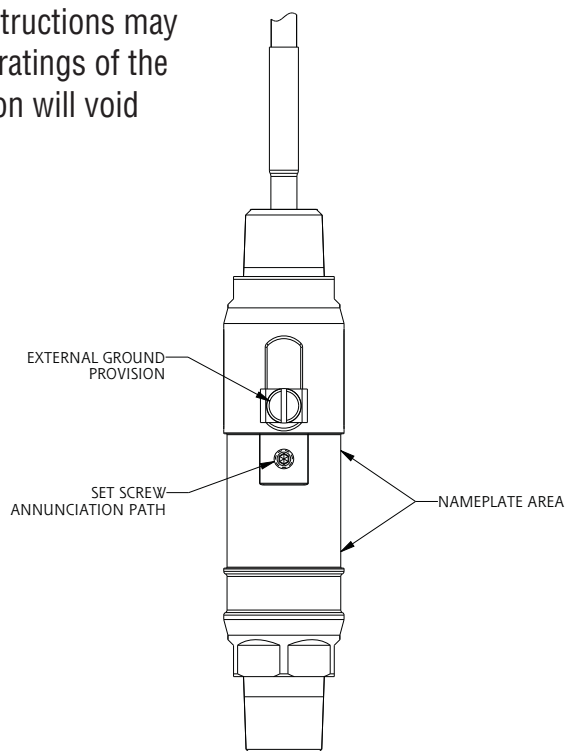

Horizontal Installation

- 1 The following figure depicts the proper horizontal installation profile; with the external ground provision and set screw (annunciation path) oriented downward.
- 2 The nameplate (tag) should not cover the set screw. Align the nameplate slot with the set screw; i.e., the set screw should be visible in the nameplate slot.

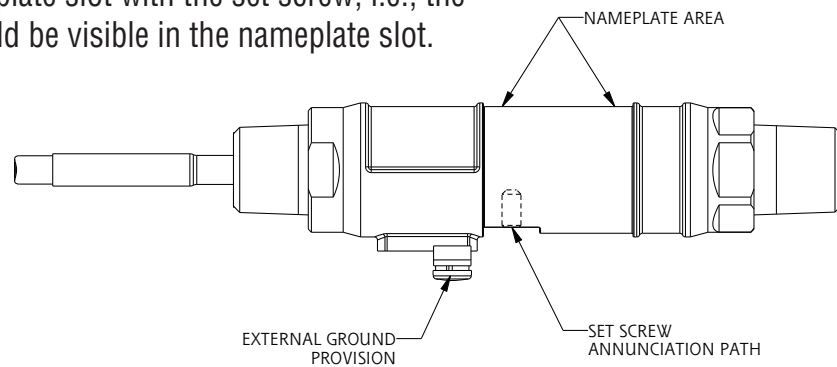

Electrical Termination - 3800-C

Drawing 0190315

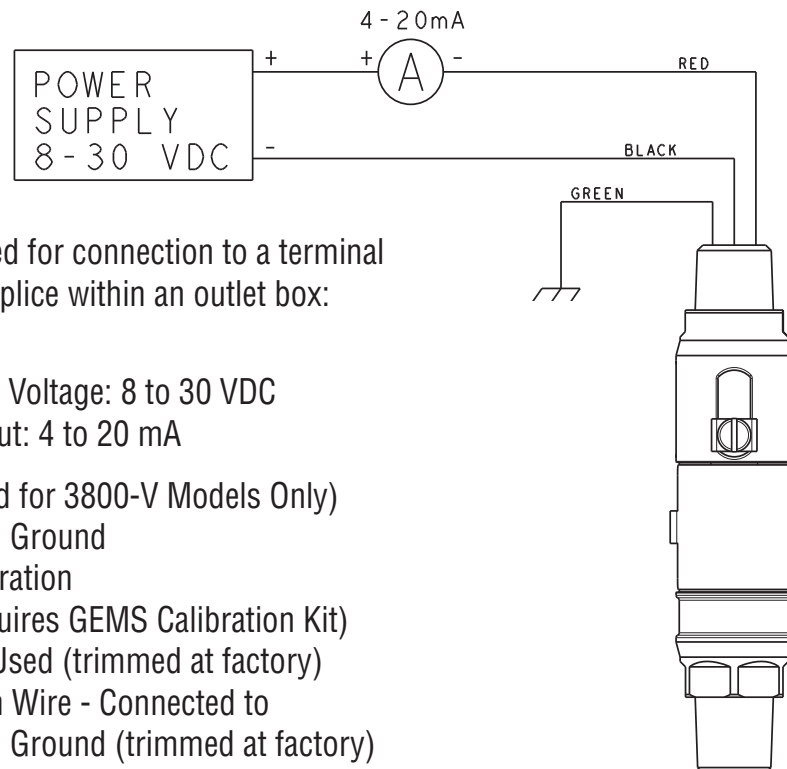

72" flying leads are provided for connection to a terminal strip within a cabinet or a splice within an outlet box:

Red (+)	} Loop Voltage: 8 to 30 VDC Output: 4 to 20 mA
Black (-)	
Blue	(Used for 3800-V Models Only)
Green	Earth Ground
White	Calibration (Requires GEMS Calibration Kit)
Brown	Not Used (trimmed at factory)
Bare	Drain Wire - Connected to Earth Ground (trimmed at factory)

NOTE: An external ground screw is included for additional earth ground connection.

**Formula for determining
maximum loop resistance**

$$R_L \text{ (MAX)} = \frac{V_{\text{Supply}} - 8V}{20\text{mA}}$$

Electrical Termination - 3800-V

Drawing 0190315

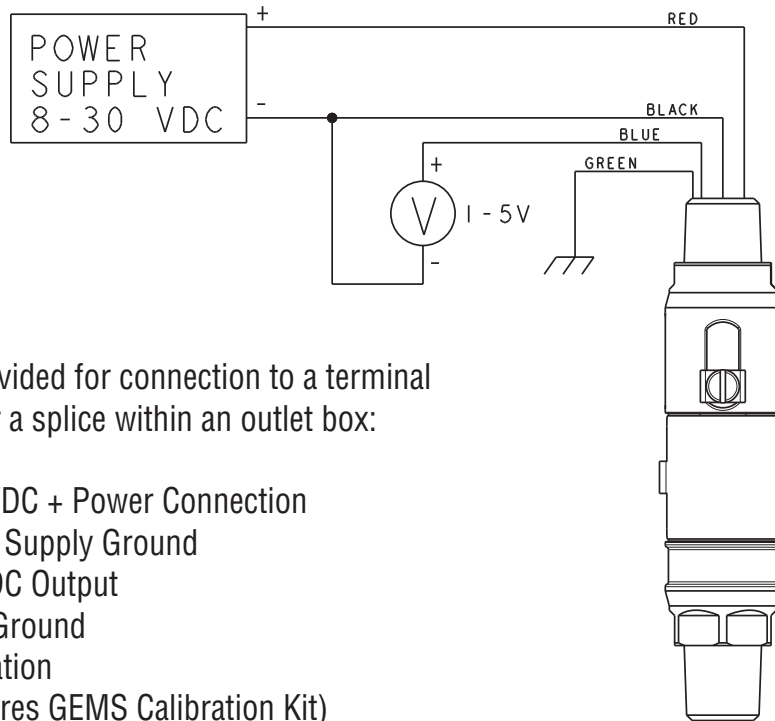

72" flying leads are provided for connection to a terminal strip within a cabinet or a splice within an outlet box:

Red (+)	8-30 VDC + Power Connection
Black (-)	Power Supply Ground
Blue	1-5 VDC Output
Green	Earth Ground
White	Calibration (Requires GEMS Calibration Kit)
Brown	Not Used (trimmed at factory)
Bare	Drain Wire - Connected to Earth Ground (trimmed at factory)

NOTE: An external ground screw is included for additional earth ground connection.

Operation

Once the transmitter is installed and wired into a control or display loop, it is ready for use. Before applying power, check that the polarity and excitation voltage are correct.

Dimensions

*Dimensions are for reference only.
Contact the factory
for certified drawings
for a particular model number.*

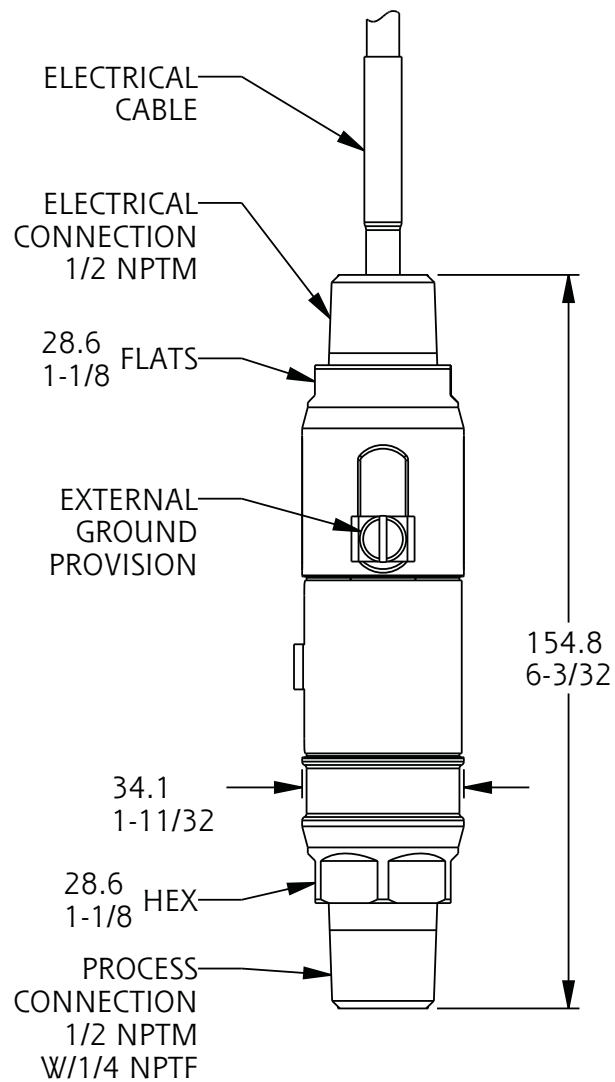

Linear = mm/inches

Drawing 0091438

Maintenance

The 3800 contains no user serviceable parts and cannot be repaired on site. It must be returned to the factory. Disassembly of the instrument by unauthorized persons will invalidate the warranty. If there is a risk of debris accumulating in the pressure port, it should be cleaned. Care and caution must be taken when cleaning the pressure port to prevent damage to the diaphragm.

ATEX Marking Details

For ATEX Certified Models

Drawing 720524G

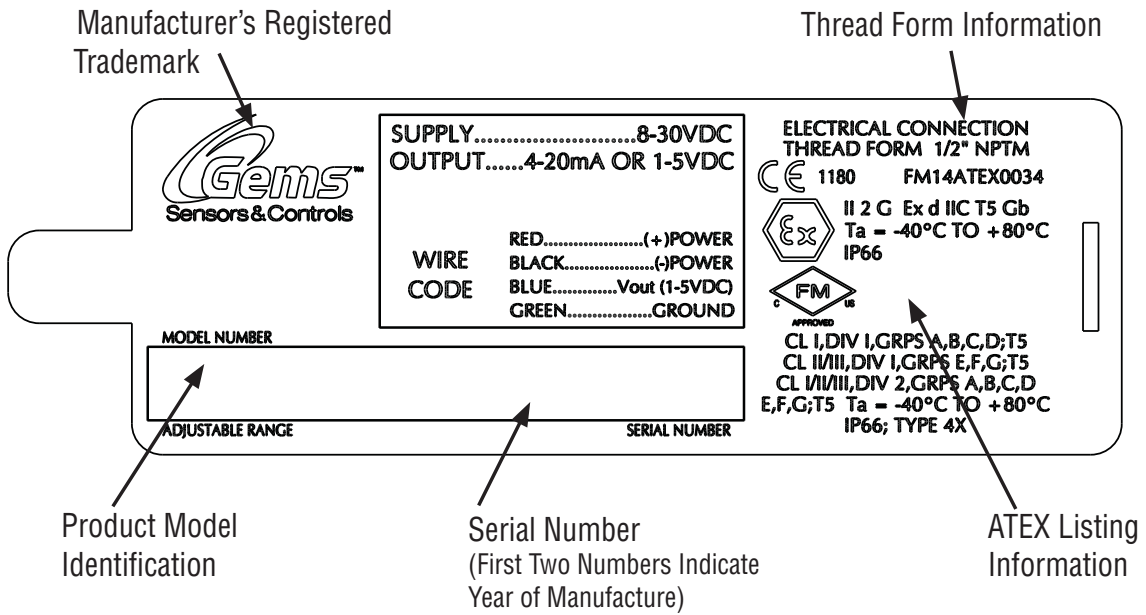



1 Cowles Road, Plainville, CT 06062 ■ 800-376-1600 ■ gemssensors.com