

# Warrick® Series 26NM Control Installation and Operation Bulletin

This bulletin should be used by experienced personnel as a guide to the installation of the Series 26NM Control. Selection or installation of equipment should always be accompanied by competent technical assistance. We encourage you to contact Gems Sensors or a representative if further information is required.

## Specifications

**Control Design:** Solid-state components enclosed in a clear Lexan plug-in style housing. Not NEMA Rated.

**Contact Design:** 1 SPST (1 form A), N.O. Non powered contacts.

**Contact Ratings:** 10A @120/240-VAC resistive (120°F), 1A @120/240VAC resistive (150°F), 1/3 Hp @ 120/240-VAC (120°F).

**Contact Life:** Mechanical -5 million operations Electrical - 100,000 operations minimum at rated load

**Supply Voltage:** Factory Configured: **24V, 120V, 220V, or 240V AC** +10%/-15% of nominal, 50/60 Hz. Factory Configured: **208V/240V Model:** 187V Min to 242V Max, VAC 50/60 Hz

**Power Consumption:** 24/120/220/240-VAC with relay energized - 4.4 VA.

**Secondary Circuit:** 2.3 VAC RMS voltage on probes, < 1 milliampere source capability.

**Sensitivity:** Factory programmed to 4.7K, 10K, 26K, 50K, or 100K Ohms

**Operating Ambient Temperature Range:** -40°F to +150°F (-40°C to +65°C)

**Terminals:** All connections made with screw-clamp terminals.

**Time Delays:** Standard LLCO, 0.5 sec. on rising level, 3 sec. on falling level. Optional 0-90 sec. time delays in 1-sec. increments for rising and falling.

**Listings:** Control carries U.L. Limit Control Listing (UL-353) for 24VAC and 120VAC Line Powered units only (220VAC, 240VAC, 208/240VAC units not rated).

## Installation

1. Install octal socket in appropriate enclosure using two #6 or #8 screws.
2. Install rail mount socket on appropriate rail (DIN mount) in appropriate enclosure if applicable.
3. Wire control per wiring diagram following N.E.C and local codes.
4. Install control module in socket

### Sensitivity vs. Maximum Probe Wire Distance\*

SENSITIVITY CHARACTER	SENSITIVITY (K-OHMS)	Distance
A	4.7	900
B	10	600
C	26	250
D	50	100
E	100	50

\* Based on type MTW or THHN wire, #14 or #16 AWG

## Dimensional Drawing

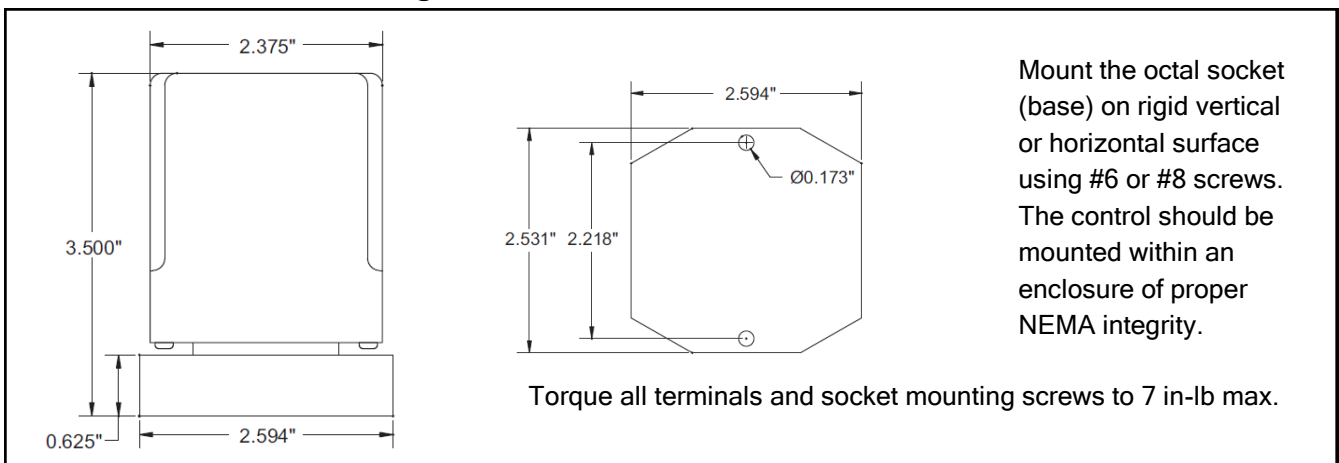

Mount the octal socket (base) on rigid vertical or horizontal surface using #6 or #8 screws. The control should be mounted within an enclosure of proper NEMA integrity.

Torque all terminals and socket mounting screws to 7 in-lb max.

# Wiring Diagram

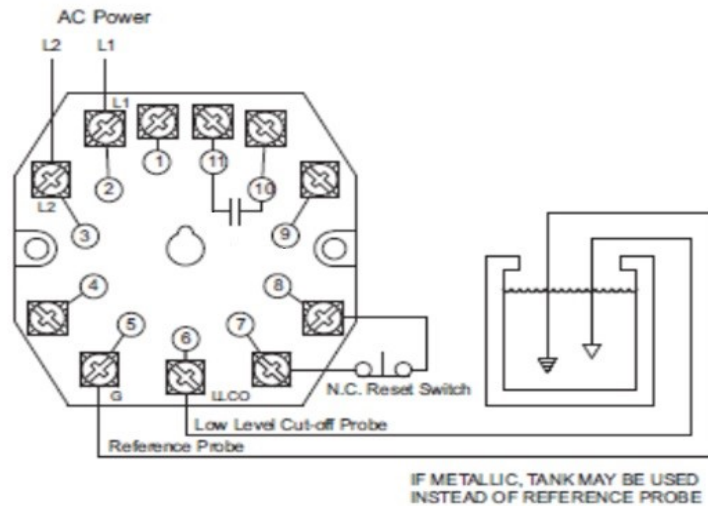

## Operation

**AUTOMATIC RESET** (Reset Switch terminals not wired) When the liquid rises to the electrode on terminal LLCO, the control energizes, changing state of the load contacts. (LED will be lit) The control remains energized until the liquid level recedes below electrode on terminal LLCO. The control then de-energizes, (LED will not be lit) returning load contacts to original state. Unless otherwise specified, there is a three second time delay on decreasing level. Liquid must be below probe on terminal LLCO for a full three seconds before control de-energizes.

**MANUAL RESET** (Normally closed pushbutton installed across reset terminals) When the liquid rises to the electrode on terminal LLCO, the control will remain de-energized until the pushbutton is depressed. Upon Reset Switch activation, the control will energize, (LED will be lit) changing the state of the contacts. The control remains energized until the liquid level recedes below electrode on terminal LLCO. The control then de-energizes, (LED will not be lit) returning load contacts to their original state. Unless otherwise specified, there is a three second time delay on decreasing level. Liquid must be below probe on terminal LLCO for full three seconds before control de-energizes. **Operator to wait 5 full seconds after power is applied before pressing reset switch (if manual reset is used).**

**MANUAL RESET OPTIONAL POWER OUTAGE FEATURE** (Normally closed pushbutton across reset terminals) Control will auto-recover from a power loss. With liquid present on LLCO electrode at a power outage event, the control will de-energize and will automatically re-energize upon return of power with liquid present on the probe at power-up. However, if loss of liquid is sensed on power-up, the control will remain de-energized until liquid again rises to electrode and pushbutton is depressed. The control will not attempt to auto-recover from a power outage if no liquid was present on the probe at power loss.

### TEST FEATURE

Allows LLCO circuit to be tested without the need to drop the water level in the boiler to create a dry probe condition. Holding down the reset button for 3 seconds will allow the LLCO circuit to trip, simulating a dry probe. The controller will return to normal operation once the reset button is pressed a second time.

**LED STATUS INDICATOR** In normal operation, the LED

on the control will either be on or off depending on the controller state. On-board microprocessors continuously monitor for fault conditions. In the event a fault is detected, the LED will blink a pattern indicating the fault type. If you experience an inoperable control and the LED is blinking, attempt to leave the control in the blinking state and contact the factory for assistance.

26NMXXXXX-XX-XX

- Time Delay Increasing Level: 0-90 seconds, Blank = 0 seconds.
- Time Delay Decreasing Level: 0-90 seconds, Blank = 3 seconds.
- Optional Character: see Chart
- Enclosure: 0-None, 1-NEMA 1, 2-NEMA 4
- Socket Style: A-11 Pin Octal, B-Din Mount, M-NONE, Module Only
- Supply Voltage: 1-120VAC (+10%/-15%), 2-240VAC (+10%/-15%), 3-24VAC (+10%/-15%), 5-220VAC (+10%/-15%), 8-208/240VAC (187 to 242 VAC absolute Range)
- Mode/Sensitivity: A-4.7K, B-10K, C-26K, D-50K, E-100K

	N.C. Pushbutton	Power Outage	Test Feature
A	X	X	X
B			X
C	X		
E		X	
F	X	X	
Y	X		X
Z		X	X
0	No Option		