

Continuous Level Transmitters

XM-700 Analog Output (Proportional Voltage)
XT-700 Signal Conditioned Output (4-20mA, 0-5 VDC, 0-12 VDC)

Designed for continuous liquid level sensing, Gems transmitters are considered "components".

Operating Principle

The XM/XT-700 utilizes reed switch/magnet technology. A magnet-equipped float rises or lowers with corresponding liquid level. The magnetic field generated from the float actuates a series of reed switches mounted within a sealed hollow tube. The series of reed switches is combined with resistors to form a voltage divider.

When regulated DC voltage is applied to an XM-700, the resulting voltage output is directly proportional to liquid level. An XT-700 is an XM-700 with a signal conditioned output, for use in applications that require unregulated input voltage or current output.

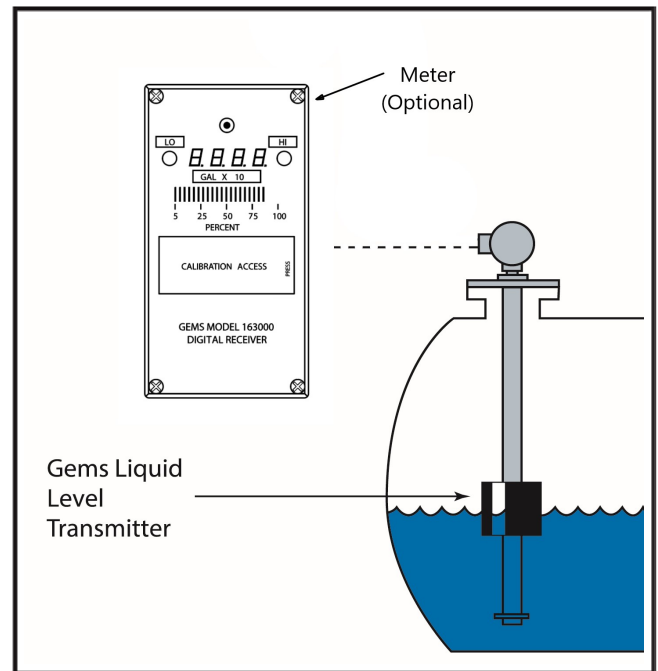

Installation/Mounting

Units operate normally in any attitude, from vertical to a 30° inclination, up or down.

Thread Treatment

Sealing: When threading metal threads into a metal coupling, pipe sealant or Teflon[®] tape is recommended.

Tightening: When threading a metal sensor into a metal coupling, the installer should use a suitable wrench and tighten the threads 1-1/2 turns past hand-tight.

Wiring Diagrams

**XM-700 Wiring Diagram
Analog Output (Proportional Voltage)**

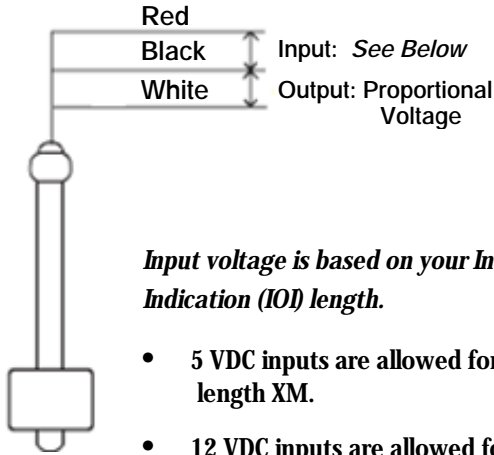

Input voltage is based on your Inches of Indication (IOI) length.

- 5 VDC inputs are allowed for any IOI length XM.
- 12 VDC inputs are allowed for IOI lengths LONGER than 2.5”.
- 24 V DC inputs are allowed for IOI lengths LONGER than 7”.

**XT-700 Wiring Diagram
(4-20mA Output)**

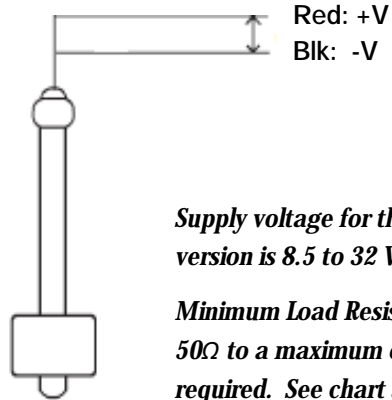

Supply voltage for the 4-20mA version is 8.5 to 32 VDC.

Minimum Load Resistance of 50Ω to a maximum of 1175Ω is required. See chart at bottom of page 3 for supply voltages vs resistance.

**Stem-Mounted Signal Conditioner
XT-700, 0-5 VDC Output**

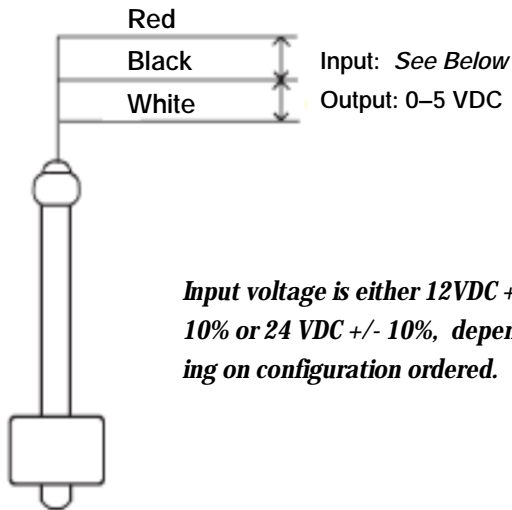

Input voltage is either 12VDC +/- 10% or 24 VDC +/- 10%, depending on configuration ordered.

**Stem-Mounted Signal Conditioner
XT-700, 0-10 VDC Output**

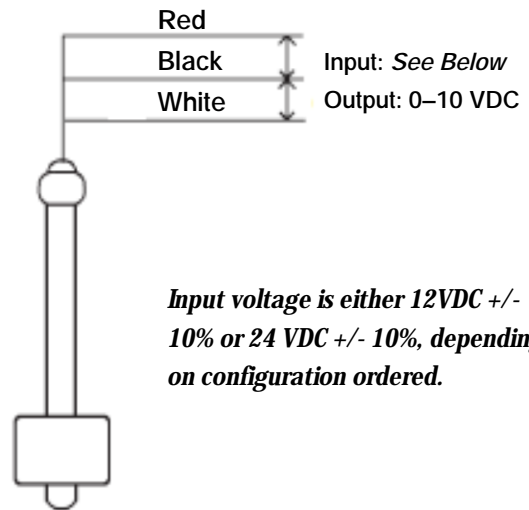

Input voltage is either 12VDC +/- 10% or 24 VDC +/- 10%, depending on configuration ordered.

Calibration

The signal conditioner on your XT-700 has been Factory-set. You do not need to calibrate.

Troubleshooting

Proportional version:

Verify proper wiring and power supply. If transmitter is not functioning properly, isolate the transmitter from the system and wire per Fig. 1. Assuming you have a standard Top-Mounted unit, the meter should read 0VDC with the float at the bottom and your input voltage (for example 5VDC) with the float at the top of transmitter. If unit is still not operating properly, please consult Factory for further troubleshooting details.

Signal Conditioner version:

Verify proper wiring and power supply. If transmitter is not functioning properly, isolate the transmitter from the system and wire per Fig. 2. Assuming you have a standard Top-Mounted unit, the meter should read 0VDC with the float at the bottom and either 5VDC or 10VDC (depending on your configuration) with the float at the top of transmitter. If unit is still not operating properly, please consult Factory for further troubleshooting details.

4-20 mA version:

Verify proper wiring, power supply, and loop resistance. If transmitter is not functioning properly, isolate the transmitter from the system and wire per Fig. 3. Assuming you have a standard Top-Mounted unit, the meter should read 4mA with the float at the bottom and 20mA with the float at the top of the transmitter. If unit is still not operating properly, please consult Factory for further troubleshooting details.

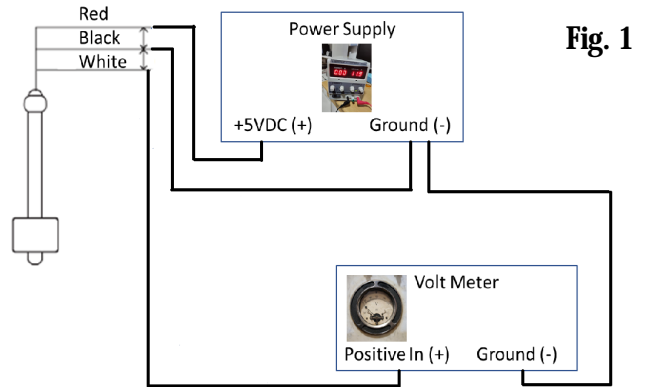

Fig. 1

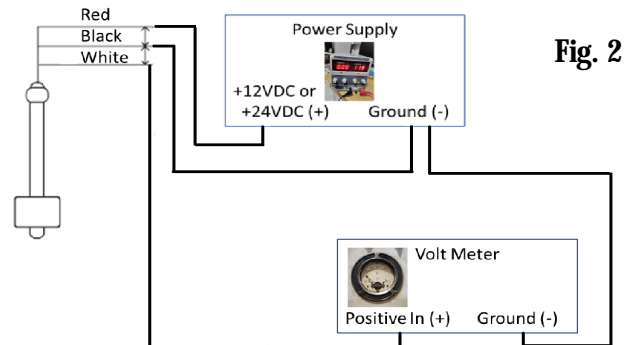

Fig. 2

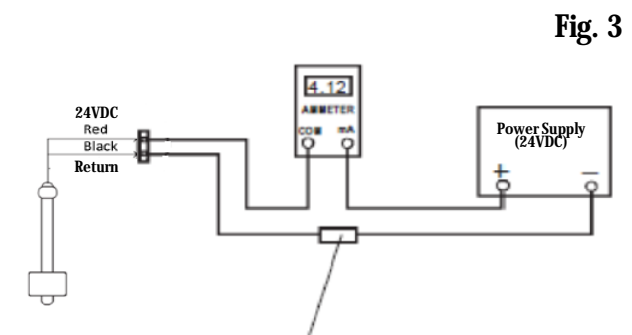
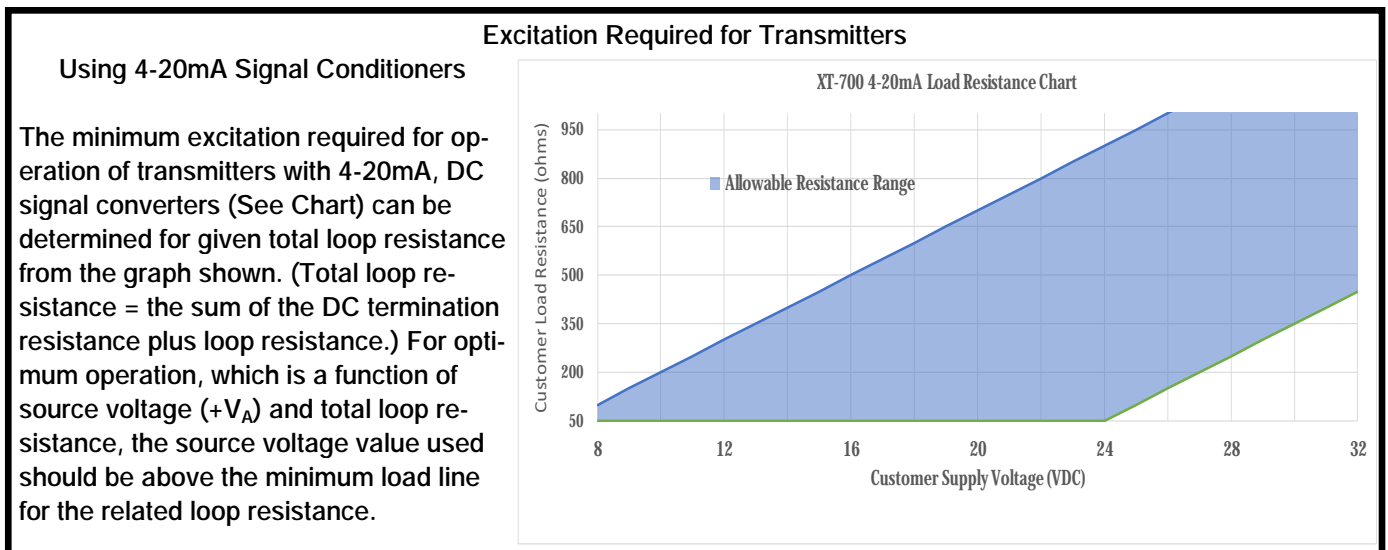

Fig. 3

Choose loop resistance (RL) to match application



Important Points!

Product must be maintained and installed in strict accordance with the National Electrical Codes and Gems technical brochure, instruction bulletin, and any applicable electrical code in the country in which the product is installed. Failure to observe this warning could result in serious injuries or damages.

For hazardous area applications involving such things (*but not limited to*) ignitable mixtures, combustible dust and flammable materials, use an appropriate intrinsically safe interface device.

****WARNING:** To prevent ignition of flammable or combustible atmospheres, disconnect power before servicing.

The pressure and temperature limitations shown on the individual catalog pages and drawings for the specified level sensors must not be exceeded. These pressures and temperatures take into consideration possible system surge pressures/temperatures and their frequencies.

Selection of materials for compatibility with the media is critical to the life and operations of Gems level sensors. Take care in the proper selection of materials of construction: particularly wetted materials.

Electrical entries and mounting points in an enclosed tank may require liquid/vapor sealing.

Physical damage sustained by the product may render it unserviceable.

Warranty

Gems Sensors, the seller, warrants its products to be free from defects in material and workmanship in normal use and service for a period of one year from date of shipment. Gems Sensors reserves the right and option to refund the purchase price in lieu of repair or replacement upon evaluation of the returned original part. Modification, misuse, attempted repair by others, improper installation or operation shall render this guarantee null and void. Imo Industries Inc., Gems Sensors, makes no warranty of merchantability or fitness for a part or purpose.

Limit of Liability: In no circumstances shall Gems Sensors be liable for special, consequential or exemplary damages of any kind or character, including contract, tort, and strict liability in tort and contract. Equipment sold by Gems Sensors is not intended for use in a nuclear installation, nor shall it be used as a "Basic Component" as same is defined under Part 21, Title 10 of the code of Federal Regulations. In the event of such use, you agree to indemnify and hold us harmless from any and all subsequent liabilities and responsibilities which might arise in connection with such use.