

890 Series – 3A Sanitary Pressure Transducer

- ▶ For Clean-In-Place (CIP) and Sterilize-In-Place (SIP)
- ▶ 0.20% Full Scale Accuracy
- ▶ No Liquid Fill Diaphragms

The 890 Series meets 3A sanitary design standards and is fully sealed to withstand external high pressure washdowns. These units are packaged in rugged welded stainless steel housings and are exceptionally insensitive to vibration, shock and environmental extremes. A small size and tri-clover sanitary pressure fitting allow direct mounting in most CIP and SIP installations. Other features include IC-based circuitry, a 1/2" NPT conduit fitting and shielded cable with vent tube. Sealed screws provide access to zero and span adjustments.

Specifications

Input	
Pressure Range	Vacuum to 1000 psig
Proof Pressure	see ordering chart
Burst Pressure	see ordering chart
Fatigue Life	>1 million cycles
Performance	
Output	4-20 mA (2 Wire)
Supply Voltage (Vs)	18-38 VDC
Accuracy	0.20% FS
Thermal Error Zero	0.02% FS/°F (0.036%FS/°C)
Thermal Error Span	0.02% FS/°F (0.036%FS/°C)
Compensated Temperatures	20°F to 180°F (-7°C to +80°C)
Operating Temperatures	-40°F to +260°F (-40°C to +125°C)
Storage Temperatures	-65°F to +260°F (-54°C to +127°C)
Zero Tolerance	1% FS (±0.5 mA adjustable)
Span Tolerance	1% FS (±0.5 mA adjustable)
Maximum Loop Resistance	(Vs-18) x 50
Response Time	10 ms
Mounting Effects	0.15% FS (.25% FS for 1.5" Tri-Clover)
Mechanical Configuration	
Pressure Port	1.5" or 2" Tri-Clover Sanitary Fitting
Wetted Parts	316 Stainless Steel
Electrical Connection	1/2" NPT Conduit Fitting and Strain Relief with 15 ft. Cable
Enclosure	Stainless Steel
Vibration	10g Peak Sinusoidal, 50 to 1000 Hz
Acceleration	10g
Shock	50g
Approvals	Meets 3-A Sanitary Standards
Weight	8 oz



CE

Applications

- Food Processing
- Dairy & Beverage Processing
- Pharmaceutical Processing
- Sanitary Pipelines

How They Operate

A stainless steel diaphragm and an insulated electrode form a variable capacitor. Pressure on the diaphragm alters the sensor's capacitance, which is then detected and converted to a highly accurate linear 4-20 mA signal by electronic circuitry featuring Gems' patented charge-balance principle. Low hysteresis, very stable operation and negligible clamping effect are inherent.

Dimensions

1.5" Fitting

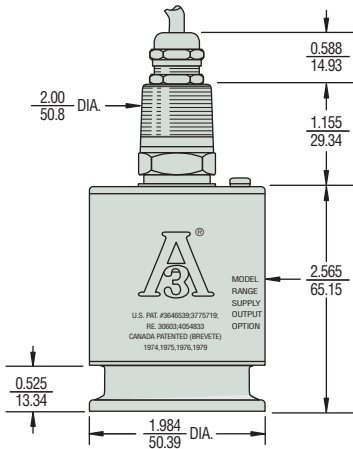

2" Fitting

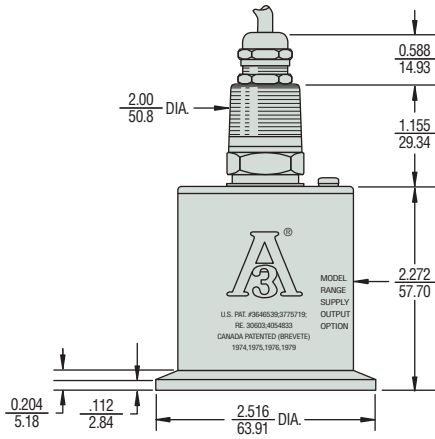

Gems adheres to strict quality standards including MIL-1-45208A and ANSI-2540-1.

How to Order

Order as 890 Series Sanitary Pressure Transmitters. Specify Pressure Range (tabulated below), Fitting Size and any Options. Use **bold** characters to construct a product code.

SELECT

C890 - 10 - 1.5 - * - * - * - *

1. Series **C890** - 890 Series

2. Pressure Ranges

2" Tri-Clover Sanitary Fittings				1.5" Tri-Clover Sanitary Fittings		
Operating Range psig	in. H ₂ O	Proof psig	Burst psig	Operating Range psig	Proof psig	Burst psig
1	22.7	50	100	30	1000	1200
2	55.4	100	150	60	1000	1200
5	138.4	150	200	100	1000	1200
10	276.8	150	200	300	1000	1200
15	415.2	150	200	500	1000	1500
30	830.4	150	300	1000	1250	2400
60	1160.8	180	400	-14.7 to 15	1000	1200
100	2768.0	200	400	-14.7 to 45	1000	1200
150	4152.0	225	400			
-14.7 to 15	-407 to 415	150	300			

3. Pressure Port
1.5 - 1.5" Tri-Clover Sanitary Fitting
2.0 - 2" Tri-Clover Sanitary Fitting

4. Options (*Add as suffix to base part code as needed)
715 - ±0.1% FS accuracy
884 - 20 Ra finish
911 - Etched metal stainless steel tag
 Cable Length:
816-825 - For cable lengths of 16 to 25 feet (15 ft. is standard).
 Please specify cable length by code (e.g., 820 for 20 ft. cable).
 Consult factory for cable longer than 25 feet.
 Calibration Certificate:
901 - 11-point calibration certificate.

PRESSURE TRANSDUCERS