

Paddle-Type Flow Switches FS-550 Series

Before Installing Unit . . .

Paddle length establishes approximate actuation setting of flow switch. Cut off paddle at proper pipe size mark on paddle for system pipe line size and the desired flow setting (**See charts on back**). For flow setting other than standard, cut off paddle at intermediate point.

Specifications . . .

Wetted Materials:	
Housing	Brass or 316 SS
Paddle	302 SS
Spring	316 SS
Other Wetted Parts	Ceramic & Teflon®
Operating Pressure, Max	2000 psig
Pressure Drop	3 psig, Max.
Operating Temperature	-30°F to +300°F (-34.4°C to +148.9°C)
Set Point Accuracy	±25%
Switch:	
Standard	SPDT, 20 VA
Uniflow	SPST, 20 VA
Repeatability	±5%
Electrical Termination	No. 18 AWG, 24"L., Polymeric Lead Wires

Electrical Connection . . .

Wire leads and 1/2" NPT for conduit connection are provided at top of unit.

Typical Wiring Diagram . . .

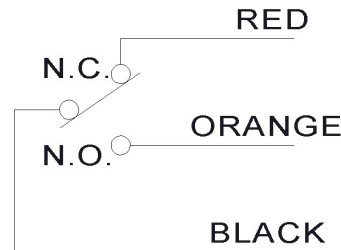

CE This product is suitable for Class I and Class II applications only, per the requirements of standard EN60730 and any additional specific requirements for a particular application or medium being sensed. Class I compliance of metal bodied units requires a ground connection between the metal body and the earthing system of the installation. Class I compliance of plastic bodied units in contact with a conductive medium requires that the medium be effectively earthed so as to provide an earthed barrier between the unit and accessible areas. For class III compliance, a supply at safety extra-low voltage (SELV) must be provided. Please consult the Factory for compliance information on specific part numbers.

European Pressure Directive

The product is designed and manufactured in accordance with Sound Engineering Practice as defined by the Pressure Equipment Directive 97/23/EC. This product must not be used as a "safety accessory" as defined by the Pressure Equipment Directive, Article 1, Paragraph 2.1.3. The presence of a CE mark on the unit does not relate to the Pressure Equipment Directive.

Dimensions

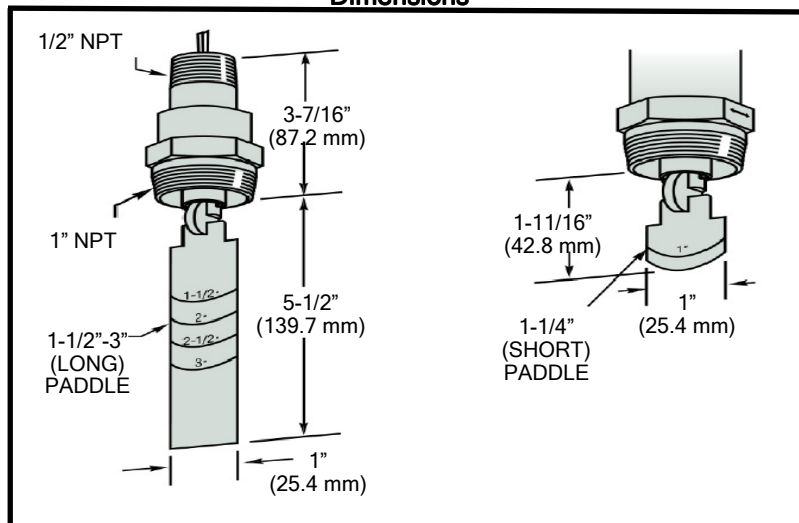

To Install Unit . . .

Installs in a standard pipe tee or reducing fitting. Mounting is 1" NPT. Locate flow switch in system to allow at least three pipe diameters of straight, horizontal piping in both directions. Install unit in vertical position, lead wires up, in standard pipe tee or reducing fitting. Be sure flow arrow on housing is parallel with pipe run. Use standard pipe fitting procedures for installation. Use tape to seal the 1" NPT.

NOTE: FS-550 units are not recommended for use with 1" plastic tees.

Maintenance . . .

Occasional cleaning to remove excessive particle build-up is the only maintenance normally required. Remove unit from system to clean, or to check operation (by manually actuating paddle).

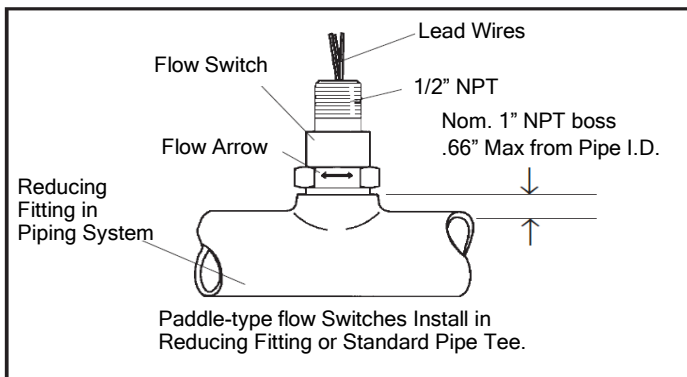

IMPORTANT NOTE

Recommended pipe is Sched. 40. Dimensions shown must be maintained to allow for full paddle swing when standard NPT tolerances are met.

Maximum height of boss from pipe or tee I.D. is .66". For proper operation of switch, do not exceed .66".

Standard Actuation and De-Actuation Set Points

Short Paddle Unit	Pipe Size Marked at Paddle Cut -Off Point	Pipe Line Sizes											
		1-1/4"		1-1/2"		2"		2-1/2"		3"		4"	
		Approximate Actuation and De-Actuation Flow Rates-GPM Water											
		Act.	De-Act.	Act.	De-Act.	Act.	De-Act.	Act.	De-Act.	Act.	De-Act.	Act.	De-Act.
	1-1/4"	5	3	13	8	22	15	29	22				
Long Paddle Unit	1-1/2"			15	11	28	21	38	30				
	2"					22	15	27	20	48	38		
	2-1/2"							21	14	40	26	52	39
	3"									31	20	45	32
	4"											39	25

All flow rate tests for the "Set Points" table were conducted with the FS-550 installed in standard "T" fittings. For calculation of flow rates in pipe sizes larger than 3", a flow velocity of approximately 0.5 Ft. per Sec. actuates the switch with a full length (5") paddle.

Important Points

Product must be maintained and installed in strict accordance with the National Electrical Code and Gems product catalog and instruction bulletin. Failure to observe this warning could result in serious injuries or damages.

An appropriate explosion-proof enclosure or intrinsically safe interface device must be used for hazardous area applications involving such things as (*but not limited to*) ignitable mixtures, combustible dust and flammable materials.

***Warning: To prevent ignition of flammable or combustible atmospheres, disconnect power before servicing.

Pressure and temperature limitations shown on individual catalog pages and drawings for the specified flow switches must not be exceeded. These pressures and temperatures take into consideration possible system surge pressures/temperatures and their frequencies.

Selection of materials for compatibility with the media is critical to

the life and operations of Gems flow switches. Take care in the proper selection of materials of construction: particularly wetted materials.

Life expectancy of switch contacts varies with applications. Contact Gems if life cycle testing is required.

Ambient temperature changes do affect switch set points, since the specific gravity of a liquid can vary with temperature.

Flow switches have been designed to resist shock and vibration; however, shock and vibration should be minimized.

Liquid media containing particulate and/or debris should be filtered to ensure proper operation of Gems products.

Electrical entries and mounting points may require liquid/vapor sealing if located in an enclosed tank.

Flow switches must not be field repaired.