

## DG Series – High Flow

- ▶ MOPD: 900 PSI (62 Bar)
- ▶  $C_v$  Range: 0.045 to 0.880 ( $K_v$  Range: 0.038 to 0.748)
- ▶ 10 Watts

For maximum flow in a miniature solenoid valve the DG Series delivers a wide range of  $C_v$  ( $K_v$ ) values and maximum operating pressures. The DG Series is also available in multiple body materials, seal materials, coil constructions, voltages, and wattages. Proven to perform for millions of cycles without failure, the DG valve – as with the entire valve series – is ideal for manifold configurations, sub-assemblies, and complete fluidic systems. The DG Series is the largest in a progression – AG Series and BG Series – of the highly flexible, modular design, (general purpose) valves.



### Typical Applications

- Agriculture
- Defense
- Sterilization Equipment
- Industrial Automation

### Reference

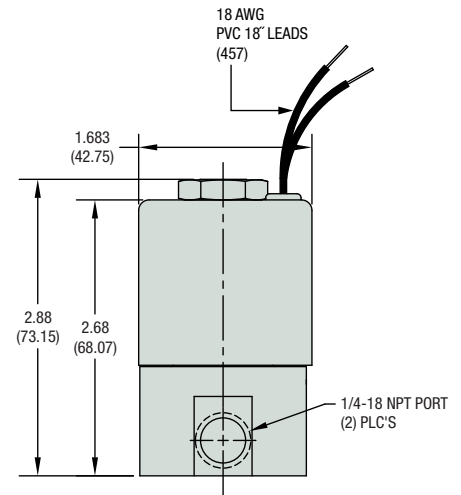
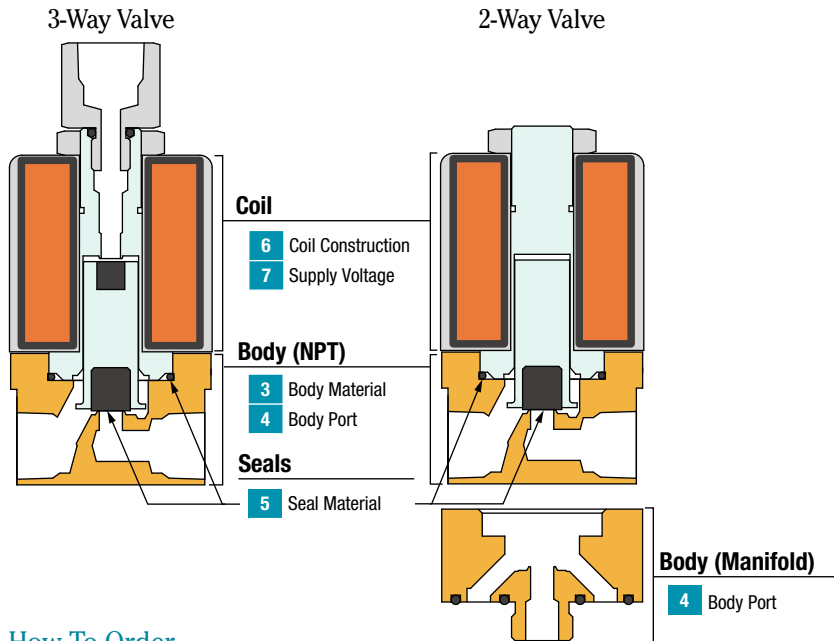

**Example Shown**  
 Part Number: DG2024-01LB-B-G1-203  
 From How to Order example below.

### How To Order

Valve Part Numbers are built from a series product codes. Use the **Bold** product codes from the choices listed on the following page to construct a complete Part Number.

<b>DG</b>	<b>20</b>	<b>24</b>	-	<b>01</b>	<b>LB</b>	-	<b>B</b>	-	<b>G1</b>	-	<b>203</b>
Series	Function	MOPD	-	Body Material	Body Port	-	Seal Material	-	Coil Construction	-	Supply Voltage

### Product Description from Example Shown Above:

#### DG2024-01LB-B-G1-203

- DG2024** = DG Series with 2-Way Normally Closed Valve **Function**; 85 **MOPD**
- 01LB** = 303 Stainless Steel **Body Material**; 1/4" NPT Female **Body Port**
- B** = Nitrile (Buna-N) **Seal Material**; (Plunger Seal and Internal O-Ring)
- G1** = Grommet Tape-Wrapped (Class B) **Coil Construction**
- 203** = 12 VDC **Supply Voltage**

# DG Series – Part Number Build

Build a Valve Part Number by filling in the boxes below using the related code numbers on this page.

<b>DG</b>	_____	_____	-	_____	_____	-	_____	-	_____	-	_____
<b>Series</b>	<b>1</b>	<b>2</b>		<b>3</b>	<b>4</b>		<b>5</b>		<b>6</b>		<b>7</b>

## 1 + 2 Valve Function & Maximum Operating Pressure Differential

Valve Function	Code	MOPD		C <sub>v</sub>		K <sub>v</sub>		Orifice			
		psig	bar	Body	Stop	Body	Stop	Body		Stop	
								inches	mm	inches	mm
2-WAY Normally Closed	2002	900	62	0.045	—	0.038	—	3/64	1.19	—	—
	2003	650	45	0.080	—	0.068	—	1/16	1.98	—	—
	2006	350	24	0.150	—	0.128	—	3/32	2.38	—	—
	2010	225	16	0.210	—	0.179	—	1/8	3.18	—	—
	2019	130	9.0	0.380	—	0.323	—	5/32	3.97	—	—
	2024	85	5.9	0.430	—	0.366	—	3/16	4.76	—	—
	2029	50	3.4	0.700	—	0.595	—	1/4	6.35	—	—
	2035	20	1.4	0.850	—	0.723	—	5/16	7.94	—	—
2037	10	0.7	0.880	—	0.748	—	3/8	9.53	—	—	
3-WAY Normally Closed	3114	175	12	0.080	0.080	0.068	0.068	1/16	1.59	1/16	1.59
	3117	150	10	0.110	0.110	0.094	0.094	5/64	1.98	5/64	1.98
	3120	125	8.6	0.150	0.150	0.128	0.128	3/32	2.38	3/32	2.38
	3124	85	5.9	0.210	0.210	0.179	0.179	1/8	3.18	1/8	3.18
	3130	45	3.1	0.380	0.380	0.323	0.323	5/32	3.97	5/32	3.97
	3133	30	2.1	0.430	0.380	0.366	0.323	3/16	4.76	5/32	3.97
	3137	10	0.7	0.700	0.380	0.595	0.323	1/4	6.35	5/32	3.97
3-WAY Normally Open	3211	200	14	0.080	0.080	0.068	0.068	1/16	1.59	1/16	1.59
	3214	175	12	0.110	0.110	0.094	0.094	5/64	1.98	5/64	1.98
	3217	150	10	0.150	0.150	0.128	0.128	3/32	2.38	3/32	2.38
	3222	100	6.9	0.210	0.210	0.179	0.179	1/8	3.18	1/8	3.18
	3229	50	3.4	0.380	0.380	0.323	0.323	5/32	3.97	5/32	3.97
	3232	35	2.4	0.430	0.380	0.366	0.323	3/16	4.76	5/32	3.97
	3236	15	1.0	0.700	0.380	0.595	0.323	1/4	6.35	5/32	3.97
3-WAY Multi Purpose	3316	160	11	0.080	0.080	0.068	0.068	1/16	1.59	1/16	1.59
	3319	130	9.0	0.110	0.110	0.094	0.094	5/64	1.98	5/64	1.98
	3321	110	7.6	0.150	0.150	0.128	0.128	3/32	2.38	3/32	2.38
	3326	75	5.2	0.210	0.210	0.179	0.179	1/8	3.18	1/8	3.18
	3331	40	2.8	0.380	0.380	0.323	0.323	5/32	3.97	5/32	3.97
	3334	25	1.7	0.430	0.380	0.366	0.323	3/16	4.76	5/32	3.97
	3337	10	0.7	0.700	0.380	0.595	0.323	1/4	6.35	5/32	3.97
3-WAY Directional Control	3410	225	16	0.080	0.080	0.068	0.068	1/16	1.59	1/16	1.59
	3413	185	13	0.110	0.110	0.094	0.094	5/64	1.98	5/64	1.98
	3417	150	10.3	0.150	0.150	0.128	0.128	3/32	2.38	3/32	2.38
	3421	110	7.6	0.210	0.210	0.179	0.179	1/8	3.18	1/8	3.18
	3428	60	4.1	0.380	0.380	0.323	0.323	5/32	3.97	5/32	3.97
	3431	40	2.8	0.430	0.380	0.366	0.323	3/16	4.76	5/32	4.76
	3435	20	1.4	0.700	0.380	0.595	0.323	1/4	6.35	5/32	3.97

### 3 Body Material

- 01 303 Stainless Steel
- XX No Body  
(4 Body Port OB only)

### 5 Seal Material

- B Nitrile
- V Viton® (1/4" orifice max)

### 7 Supply Voltages

- 203 12 VDC
- 204 24 VDC

### 4 Body Port

- LB 1/4" NPT Female
- LD 3/8" NPT Female
- MM Manifold Mount  
(1/2"-20 Stud;  
1/4" Orifice, Max.)
- OB Omit Body (operator only)\*  
(3 Body Material XX only)

### 6 Coil Construction

- G1 Grommet Housing,  
Tape-Wrapped (Class B) Lead Wires
- G5 Grommet Housing,  
Epoxy Encapsulated (Class B) Lead Wires
- S1 Epoxy Encapsulated (Class B), 1/4" Spade Terminals

\* Contact Gems for the operator orifice drawings

# DG Series – Additional Component Details & Dimensions

**1** Valve Function

Flow Schematics

**Flow Key**

- Blocked Flow
- Free Flow
- O/S = Over Seat
- U/S = Under Seat

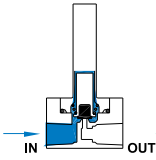
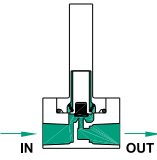
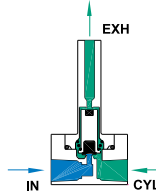
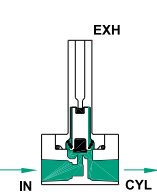
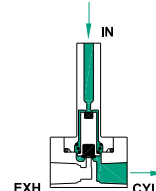
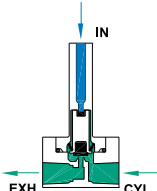
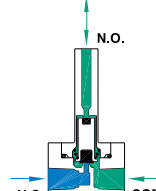
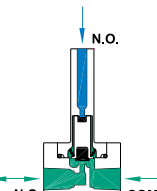
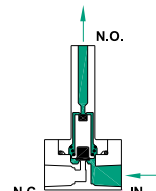
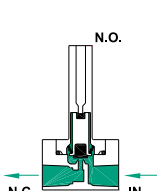
Valve Type	De-Energized	Energized
<b>2-Way Normally Closed</b>		
<b>3-Way Normally Closed</b>		
<b>3-Way Normally Open</b>		
<b>3-Way Multi Purpose</b>		
<b>3-Way Directional Control</b>		

# DG Series – Additional Component Details & Dimensions, cont.

## 4 Body Port

Note: Contact Gems for the operator orifice drawings

### Ported Bodies

#### 1/4" NPT Port (LB)

FOR 1/4", 5/16", 3/8" BODY ORIFICES

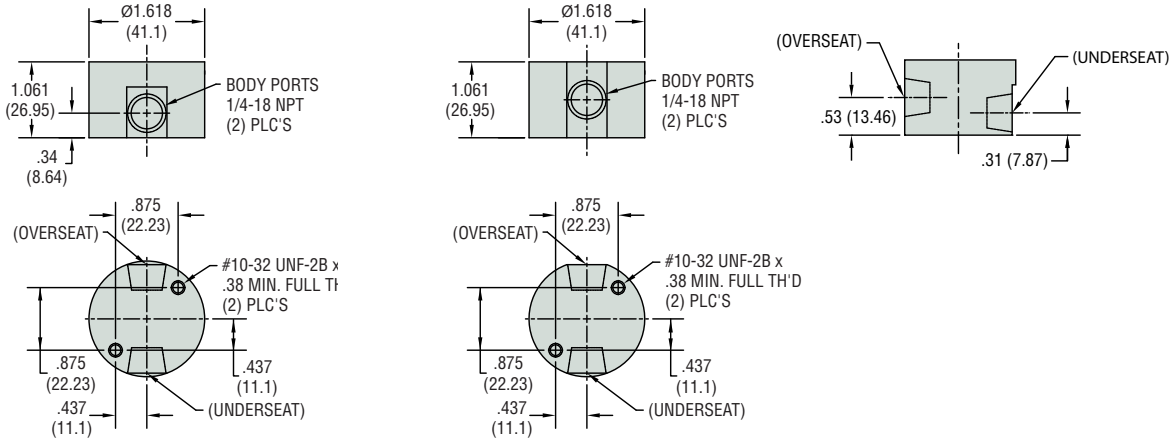

#### 3/8" NPT Port (LD)

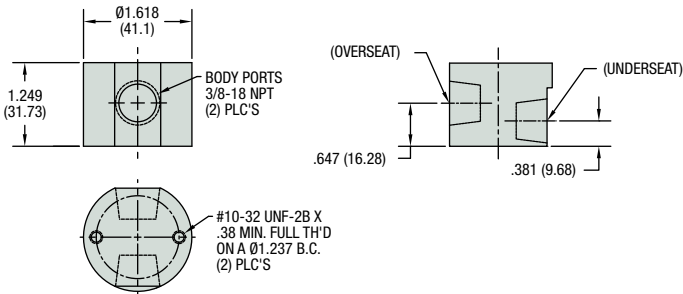

3/8-18 NPT PORTS (OPTION "LD")

# DG Series – Additional Component Details & Dimensions, cont.

## 4 Body Port (continued)

### Manifold Mounting Bodies

#### Manifold Mount 1/2"-20 Stud Body (MM)

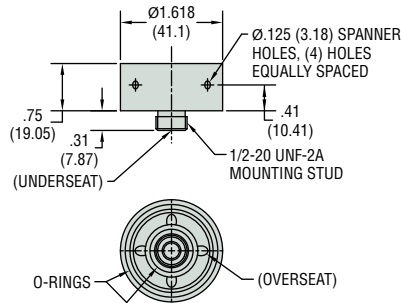

#### Manifold Preparation

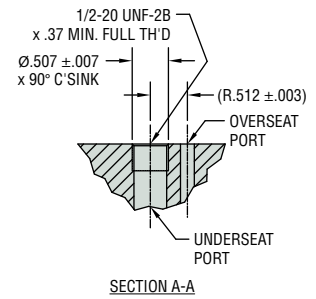
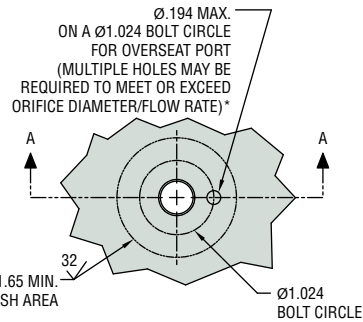

\* If the total area of overseat port is less than the orifice diameter, then the overseat is the restrictor.

Valve Type	Overseat Port	Underseat Port
2-Way N.C.	IN	OUT
3-Way N.C.	CYL	IN
3-Way N.O.	CYL	EXH
3-Way M.P.	COM	N.C.
3-Way D.C.	IN	N.C.

## 6 Coil Construction

